

Occhio

your supplies

owner's manual

Mito cosmo move mounting plate

➔ = Option 1
gerade Ausrichtung
straight alignment
alignement droit
alineación recta
allineamento rettilineo

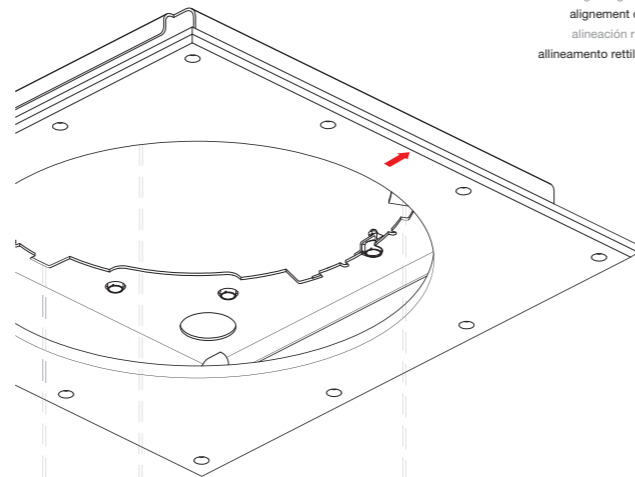

Vor der Montage die Ausrichtung
der Leuchte mit Hilfe der
Markierung bestimmen

Before mounting, determine the
orientation of the light using the
marking

Avant le montage, déterminer
l'orientation du luminaire à l'aide
du repère

Antes del montaje, determine la
alineación de la luminaria con
ayuda de la marca

Prima di procedere al
montaggio, determinare
l'allineamento dell'apparecchio
con l'aiuto della marcatura

➔ = Option 2
diagonale Ausrichtung
diagonal alignment
alignement diagonal
alineación diagonal
allineamento diagonale

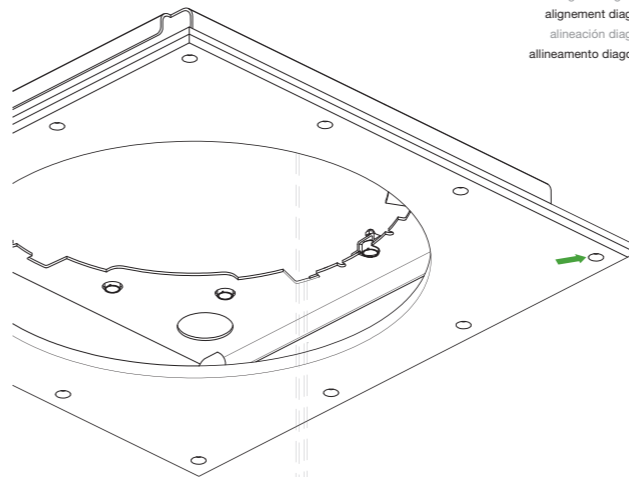

culture of light

Mito cosmo move 40

Deckenausschnitt erstellen.

Make ceiling cutout.

Effectuer la découpe du plafond.

Realizar el corte en el techo.

Realizzare apertura soffitto.

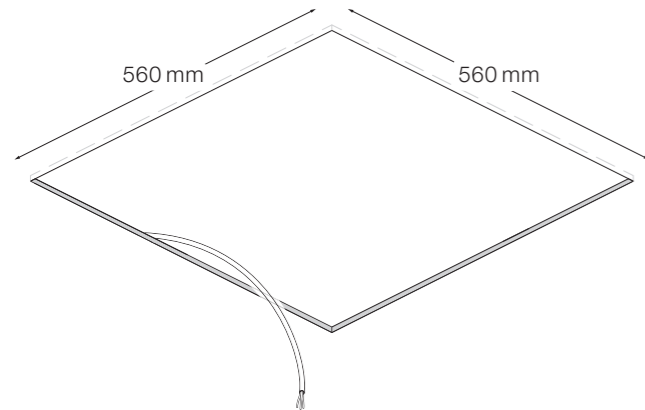

Mito cosmo move 60

Deckenausschnitt erstellen.

Make ceiling cutout.

Effectuer la découpe du plafond.

Realizar el corte en el techo.

Realizzare apertura soffitto.

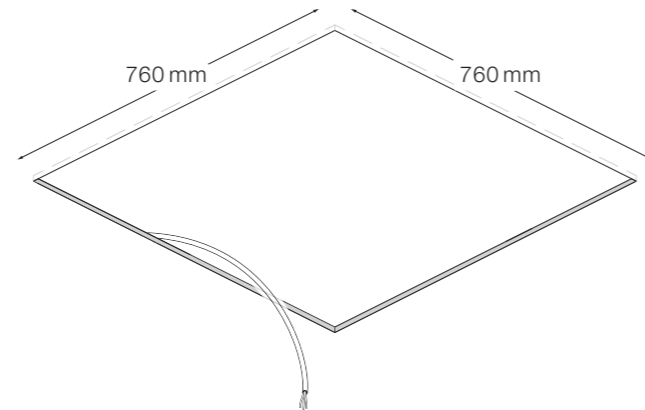

Unterkonstruktion erstellen und Einbauplatte bündig montieren!

Create sub-frame structure and set mounting plate so it is flush!

Réaliser la structure porteuse et monter la plaque de montage bord à bord.

¡Crear la subestructura y montar a ras la placa de montaje!

Realizzare la sottostruttura e montare il pannello di installazione a filo!

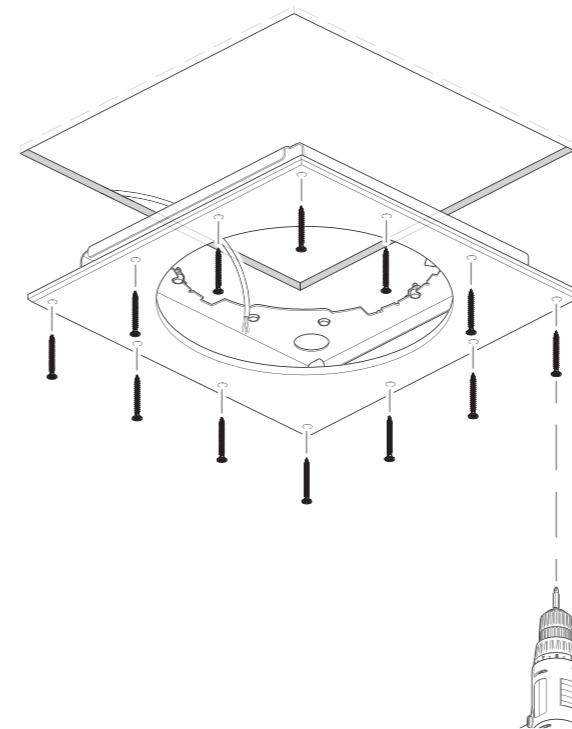

Fugen verputzen und Malerarbeiten ausführen.

Plaster joints and complete painting.

Faire les joints et réaliser les travaux de peinture.

Revocar las juntas y realizar los trabajos de pintura.

Intonacare i giunti e imbiancare.

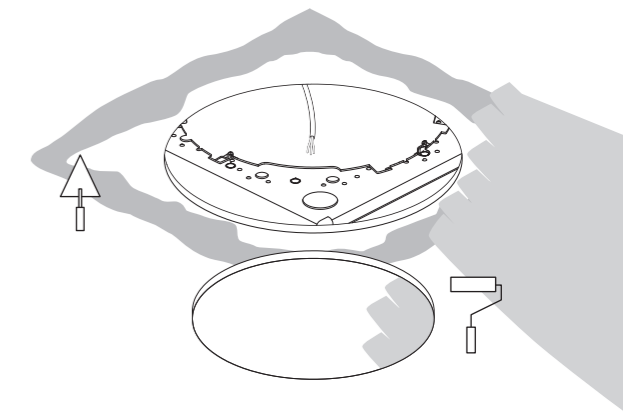

Vor der Montage alle stromführenden Leitungen vom Stromnetz trennen!

Disconnect all electrical lines from the mains before mounting!

Débrancher toutes les sources d'alimentation avant le montage !

¡Antes del montaje deben separarse de la red eléctrica todos los cables que conducen corriente!

Prima del montaggio scollegare tutti i cavi di alimentazione dalla rete elettrica!